

3. SWITCHED ACCESS

3.1 GENERAL

Switched Access Service, which is available to customers for their use in furnishing their services to end users, provides a two-point communications path between a customer's premises and an end user's premises. It provides for the use of terminating, switching, transport facilities and subscriber common lines. Switched Access Service provides for the ability to originate calls from an end user's premises to a customer's premises, and to terminate calls from a customer's premises to an end user's premises in the LATA where it is provided. Switched Access Service must be ordered separately for each LATA in which the Customer desires to originate or terminate calls.

3.2 PROVISION AND DESCRIPTION

The Company provides Feature Group B, Feature Group D and 8XX Toll-Free Switched Access Services. The service categories are differentiated by their technical characteristics and the manner in which an end user accesses them when originating calls.

3.2.1 FEATURE GROUP B

FGB Access, which is available to all customers, provides trunk side access to Company end office switches with an associated uniform 950-XXXX access code for the Customer's use in originating and terminating communications.

3.2.2 FEATURE GROUP D

FGD Access, which is available to all customers, provides trunk side access to Company end office switches with an associated uniform 10XXX access code for the Customer's use in originating and terminating communications. No access code is required for calls to a customer over FGD if the end user's telephone exchange service is arranged for presubscription to that customer.

3. SWITCHED ACCESS

3.2.3 8XX TOLL-FREE ACCESS SERVICE

8XX Toll-Free Access Service is a service offering utilizing originating trunk side Switched Access Service. The service provides for the forwarding of end user dialed 8XX calls to a Company Service Switching Point which will initiate a query to the data base to perform the Customer identification and delivery function. The call is forwarded to the appropriate customer based on the dialed 8XX number.

3.2.4 SS7 OUT OF BAND SIGNALING OPTION

SS7 Out of Band Signaling option provides the means for transmitting SS7 out of band signaling information over a communications path which is separate from the message path

3. SWITCHED ACCESS

3.3 SWITCHED ACCESS RATE CATEGORIES

There are three rate categories which apply to Switched Access Service provided by the Company: Carrier Common Line, Switched Transport and End Office Switching.

The following diagrams depict generic views of the components of Switched Access Service and the manner in which the components are combined to provide a complete access service.

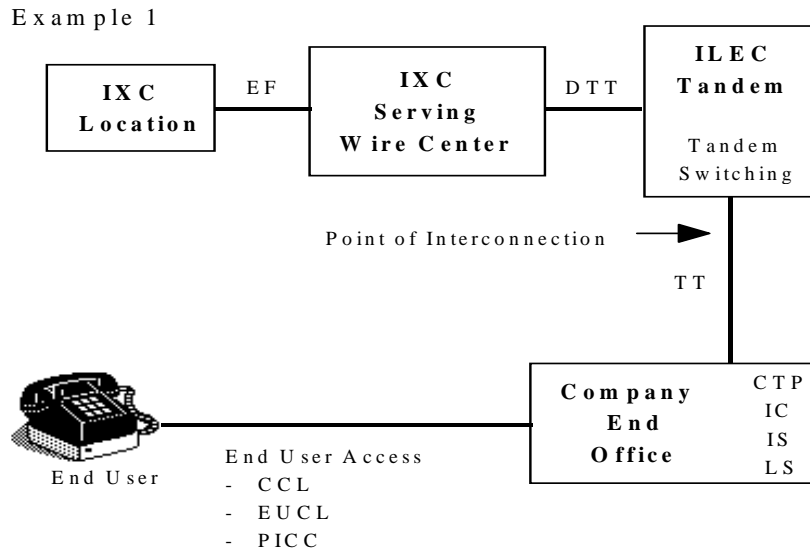

ILEC bills:

DTT - Direct Trunked Transport
EF - Entrance Facility
TS - Tandem Switching

Company bills:

End Office Rate Elements
CTP - Common Trunk Port
IC - Interconnection Charge
IS - Information Surcharge
LS - Local Switching
End User Access
CCL - Carrier Common Line
EUCL - End User Common Line [1]
PICC - Presubscribed IXC Charge [1]
Tandem Transport (TT)
Transport Termination
Transport Mileage

[1] Assessed on a flat-rated monthly basis.

3. SWITCHED ACCESS

3.3 SWITCHED ACCESS RATE CATEGORIES (Cont'd)

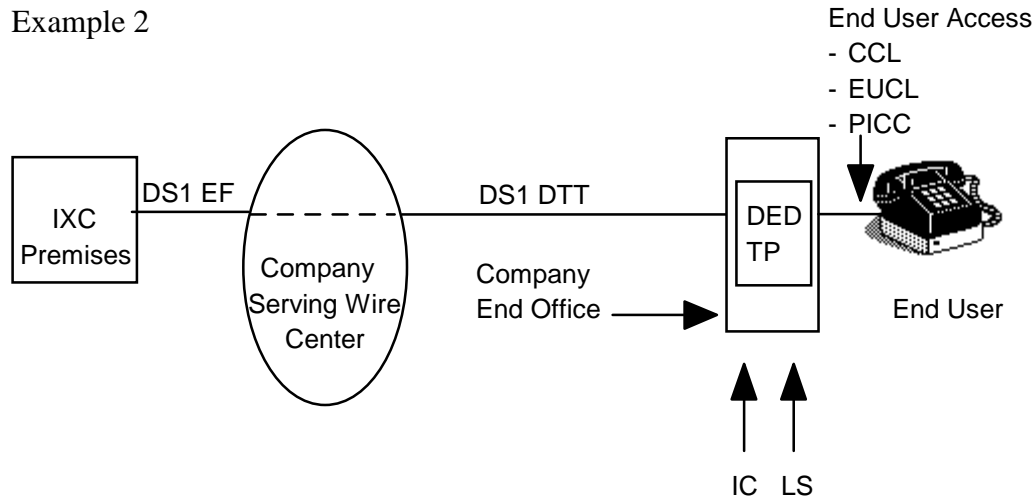

Company bills:

- EF - Entrance Facility [1]
- DTT - Direct-Trunked Transport [1]
- End Office Rate Elements
 - DED TP - Dedicated Trunk Port [1]
 - IC - Interconnection Charge
 - IS - Information Surcharge
 - LS - Local Switching
- End User Access
 - CCL - Carrier Common Line
 - EUCL - End User Common Line [1]
 - PICC - Presubscribed IXC Charge [1]
- Tandem Transport (TT)
 - Transport Termination
 - Transport Mileage

[1] Assessed on a flat-rated monthly basis.

3. SWITCHED ACCESS

3.3 SWITCHED ACCESS RATE CATEGORIES (Cont'd)

3.3.1. CARRIER COMMON LINE

The Carrier Common Line rate category provides for the use of Company common lines by customers for access to end users to furnish customer interstate communications.

A. Limitations

1. A telephone number is not provided with Carrier Common Line.
2. Detail billing is not provided for Carrier Common Line.
3. Directory listings are not included in the rates and charges for Carrier Common Line.
4. Intercept arrangements are not included in the rates and charges for Carrier Common Line.
5. All trunk side connections provided in the same combined access group will be limited to the same features and operating characteristics.

B. Rate Regulations

Where the Customer is provided with Switched Access Service under this Tariff, the Company will provide the use of Company common lines by a customer for access to end users at rates and charges as set forth in 3.7, following.

1. The Carrier Common Line charge is assessed per access minute to each Switched Access Service customer.
2. When the Customer reports interstate and intrastate use of Switched Access Service, the Carrier Common Line charge is billed only to interstate access minutes.
3. All Switched Access Service provided to the Customer will be subject to Carrier Common Line charges.

3. SWITCHED ACCESS

3.3 SWITCHED ACCESS RATE CATEGORIES (Cont'd)

3.3.2. TRANSPORT

The Transport rate category provides for the transmission facilities between the customer's premises and the end office switch(es) where the customer's traffic is switched to originate or terminate its communications.

Switched Transport is a two-way voice-frequency transmission path which may be composed of an Entrance Facility (EF), Direct-Trunked Transport (DTT) Facility or Tandem Transport. The types of facilities available for EF and DTT facilities are described in B.3., following

A. Tandem Transport

The Tandem Transport rate category provides for transmission facilities between the Company's End Office and an alternate tandem provider's network.

1. Transport Termination

The Transport termination element includes the non-distance sensitive portion of Tandem Transport and is assessed on a per-access-minute-of-use basis.

2. Transport Mileage

The Transport Mileage element includes the distance sensitive portion of Tandem Transport and is assessed on a per-access-minute-of-use-per-mile basis.

3. Tandem Switching

The Tandem Switching rate is assessed on a per access minute of use basis to all Switched Access minutes when tandem switching functions are utilized.

3. SWITCHED ACCESS

3.3 SWITCHED ACCESS RATE CATEGORIES

3.3.2. TRANSPORT (Cont'd)

B. Dedicated Transport

1. Entrance Facility (EF) Rate Category

An EF provides the communication path between a customer's premises and the Company serving wire center (SWC) of that premises for the sole use of the customer. The EF rate category is composed of a Voice Grade rate, a DS1 rate or a DS3 rate. An EF is provided even if the customer's premises and the SWC are located in the same building.

2. Direct Trunked Transport (DTT) Rate Category

DTT provides the transmission path on circuits dedicated to the use of a single customer between the customer's SWC and an end office.

The DTT rate category is composed of a monthly fixed rate and a monthly per-mile rate based on the facility provided, (i.e., Voice Grade, DS1 or DS3). The fixed rate provides the circuit equipment at the ends of the transmission paths. The per-mile rate provides the transmission facilities, including intermediate transmission circuit equipment, between the end points of the circuit. The DTT rate is the sum of the fixed rate and the per-mile rate. For purposes of determining the per-mile rate, mileage will be measured as airline mileage using the V&H coordinates method.

3. SWITCHED ACCESS

3.3 SWITCHED ACCESS RATE CATEGORIES

3.3.2. TRANSPORT

B. Dedicated Transport (Cont'd)

3. Dedicated Transport Facility Types

There are three types of facilities available to the customer for EF and DTT facilities. Each type has its own characteristics and is available with multiplexing options.

a. Voice Grade Facility

A Voice Grade facility is an electrical communications path which provides voice-frequency transmission in the nominal frequency range of 300 to 3000 Hz and may be terminated two-wire or four-wire.

b. DS1 Facility

A DS1 facility is capable of transmitting electrical signals at a nominal 1.544 Mbps, with the capability to channelize up to 24 voice-frequency transmission paths.

c. DS3 Facility

A DS3 facility is capable of transmitting electrical signals at a nominal 44.736 Mbps, with the capability to channelize up to 672 voice-frequency transmission paths.

3. SWITCHED ACCESS

3.3 SWITCHED ACCESS RATE CATEGORIES

3.3.2. TRANSPORT

B. Dedicated Transport (Cont'd)

4. Multiplexing

Multiplexing provides the capability of converting the capacity or bandwidth of a facility from a higher level to a lower level or from a lower level to a higher level. Multiplexing functions for an EF are available at a SWC. For DTT facilities, multiplexing is available at a Company end office. EF and DTT multiplexing arrangements are described following

a. DS1 to Voice Grade

DS1 to Voice Grade multiplexing is an arrangement that provides a Company multiplexer which converts a DS1 channel to twenty-four Voice Grade channels utilizing time division multiplexing. For example, the customer has the option of ordering a DS1 to Voice Grade multiplexer for a DS1 Entrance Facility at the SWC when Voice Grade DTT is requested to an end office.

b. DS3 to DS1

DS3 to DS1 multiplexing is an arrangement that converts a DS3 channel to twenty-eight DS1 channels utilizing time division multiplexing. The twenty-eight channels may be further multiplexed utilizing DS1 to Voice Grade multiplexing equipment.

3. SWITCHED ACCESS

3.3 SWITCHED ACCESS RATE CATEGORIES (Cont'd)

3.3.3. END OFFICE SWITCHING

The End Office Switching rate category provides the local end office switching and end user termination functions necessary to complete the transmission of Switched Access communications to and from the end users served by the Company's end office.

End Office Switching is comprised of one or more of the following: a Local Switching rate, a Common (shared) Trunk Port rate, a Dedicated Trunk Port rate, an Interconnection charge and an Information surcharge.

The End Office Switching rates are set forth in 3.7, following.

A. Local Switching

The Local Switching rate element provides local dial switching for Feature Groups B and D.

B. Common Trunk Port

The end office Common Trunk Port rate provides for the termination of tandem transport trunks in shared end office ports. The end office Common Trunk Port rate is assessed on a per-MOU basis to all trunkside originating and terminating access minutes utilizing tandem routing to an end office.

C. Dedicated Trunk Port

The end office Dedicated Trunk Port rate provides for the termination of a trunk to a dedicated trunk port in an end office. The rate is assessed per month for each FG trunk in service directly routed (via DTT) between the SWC and the end office.

3. SWITCHED ACCESS

3.3 SWITCHED ACCESS RATE CATEGORIES (Cont'd)

3.3.4. 8XX TOLL-FREE ACCESS SERVICE

A Customer Identification Charge applies to 8XX Toll-Free Access Service. (C)

8XX Toll-Free Access Service is a service offering originating trunk side Switched Access Service. The service provides for the forwarding of end user dialed 8XX calls to a Company Service Switching Point which will initiate a query to the database to perform the customer identification and delivery functions. The call is forwarded to the appropriate customer based on the dialed 8XX number. (C)

(D)

(D)

3. SWITCHED ACCESS

3.4 OBLIGATIONS OF THE CUSTOMER

The Customer facilities at the premises of the ordering customer shall provide the necessary on-hook and off-hook supervision.

3.4.1 ORDERING REQUIREMENTS

A. A Switched Access Service Order is used by the Company to provide a customer Switched Access Service. When placing an order for Switched Access Service, the Customer shall provide, at a minimum, information for the EF (if Company provided), the type of routing (direct or tandem), and the number of trunks to each end office. If direct routing is requested, the customer shall specify the type of facility (Voice Grade, DS1 or DS3) for the EF and DTT.

1. For Feature Group B Switched Access Service, the Customer shall specify the number of trunks and the end office. When ordering FGB trunks to an end office, the Customer must also provide the Company an estimate of the amount of traffic to be generated to and/or from each end office subtending an access tandem to assist the Company in the effort to project further facility requirements. In addition, the Customer shall also specify for terminating only access, whether the trunks are to be arranged in trunk group arrangements or provided as single trunks.

2. For Feature Group D Switched Access Service, the Customer shall specify the number of busy hour minutes of capacity (BHMC) from the Customer's premises to the end office by Feature Group and by traffic type. This information is used to determine the number of transmission paths. Customers may, at their option, order FGD by specifying the number of trunks and the end office. When a customer orders FGD in trunks, the Customer is responsible to assure that sufficient access facilities have been ordered to handle its traffic. When ordering by trunk quantities rather than BHMC quantities to an end office, the Customer must also provide the Company an estimate of the amount of traffic it will generate to and/or from each end office to assist the Company in its own efforts to project further facility requirements.

In addition, for Feature Group D with the Out of Band Signaling/SS7 signaling option, the Customer shall specify the switching point codes and trunk circuit identification codes for trunks with the Out of Band Signaling/SS7 signaling option, and the STP point codes.

3. For 8XX Toll-Free Access Service, the Customer shall order the service in accordance with the preceding provisions set forth for Feature Group D. If the Customer desires any of the optional features available with 8XX Toll-Free Access Service, the Customer shall so specify on the order for service.

3. SWITCHED ACCESS

3.4 OBLIGATIONS OF THE CUSTOMER (Cont'd)

3.4.2 SWITCHED ACCESS ORDER MODIFICATIONS

The Customer may request a modification of its Switched Access Order at any time prior to notification by the Company that service is available for the Customer's use or prior to the service date, whichever is later.

Any increase in the number of Switched Access Service trunks or busy hour minutes of capacity will be treated as a new Switched Access Order (for the increased amount only).

A. Service Date Change Charge

Switched Access Order service dates for the installation of new services or rearrangements of existing services may be changed, but the new service date may not exceed the original service date by more than 30 calendar days. If the Customer requested service date is more than 30 calendar days after the original service date, the order will be canceled by the Company and reissued with the appropriate cancellation charges applied.

B. Partial Cancellation Charge

Any decrease in the number of ordered Switched Access Service trunks or busy hour minutes of capacity ordered with a Standard or Negotiated Interval Switched Access Order will be treated as a partial cancellation and the charges as set forth in 3.5.3, following, will apply for that portion of the order that is cancelled. Partial cancellation charges do not apply to Advance Order Interval Access Orders.

3. SWITCHED ACCESS

3.4 OBLIGATIONS OF THE CUSTOMER

3.4.2 SWITCHED ACCESS ORDER MODIFICATIONS (Cont'd)

C. Expedited Order Charge

When placing a Switched Access Order for service(s) for which Standard Intervals exist, a customer may request a service date that is prior to the Standard Interval service date. A customer may also request an earlier service date on a pending Standard, Negotiated or Advance Order Interval Access Order. If the Company agrees to provide service on an expedited basis, an expedited order charge will apply.

If the Company receives a request for an expedited service date at the time a Standard Interval Access Order is placed, the expedited order charge is calculated by summing all the nonrecurring charges associated with the order and then dividing this total by the number of days in the Standard Interval. The charge is then applied on a per day of improvement basis, per order, but in no event shall the charge exceed fifty percent of the total nonrecurring charges associated with the Switched Access Order.

D. Advance Order Interval

When placing a Switched Access Order, a customer may request an Advance Order Interval for a service date of 12 to 24 months from the Application Date for the following services:

- A minimum of 24 voice grade equivalent Switched Access Service trunks or 720 BHMCs.
- Orders for less than the minimum quantities will be accommodated under Standard or Negotiated Interval provisions.

3. SWITCHED ACCESS

3.4 OBLIGATIONS OF THE CUSTOMER (Cont'd)

3.4.3 CANCELLATION OF A SWITCHED ACCESS ORDER

A. A customer may cancel a Switched Access Order for the installation of service at any time prior to notification by the Company that services available for the Customer's use or prior to the service date, whichever is later. The cancellation date is the date the Company receives written or verbal notice from the Customer that the order is to be canceled. The verbal notice must be followed by written confirmation within 10 days. If a customer's end user is unable to accept Switched Access Service within 30 calendar days after the original service date, the Customer has the choice of the following options:

- The Switched Access Order shall be canceled and charges set forth in B., following, will apply, or
- Billing for the service will commence.

If no cancellation request is received within the specified 30 calendar days, billing for the service will commence. In any event, the cancellation date or the date billing is to commence, as applicable, shall be the 30^{Original} day beyond the original service date of the Switched Access Order.

B. When a customer cancels a Standard or Negotiated Interval Switched Access Order for the installation of service, a Cancellation Charge will apply as follows:

1. When the Customer cancels a Switched Access Order, a charge equal to the estimated provisioning costs incurred at a particular date for the service ordered by the Company shall apply.
2. If the Company misses a service date for a Standard or Negotiated Interval Switched Access Order by more than 30 days, due to circumstances such as acts of God, governmental requirements, work stoppages and civil commotions, the Customer may cancel the Switched Access Order without incurring cancellation charges.
3. Cancellation or Partial Cancellation of an Advance Order Interval Switched Access Order

When the Customer cancels a Switched Access Order, the order will be withdrawn. The Advance Payment will not be credited or refunded. Any decrease in the number of ordered Switched Access Services will be treated as a partial cancellation, and the portion of the Advance Payment for the services canceled will not be credited or refunded.

3. SWITCHED ACCESS

3.5 RATE REGULATIONS

3.5.1 APPLICATION OF RATES

A. Nonrecurring Charges

Nonrecurring charges are one-time charges that apply for a specific work activity (i.e., installation or service rearrangements).

1. Installation of Service

Nonrecurring charges apply to each Switched Access Service installed. For Switched Services ordered on a per trunk basis, the charge is applied per trunk. For Switched Services ordered on a busy hour minutes of capacity basis, the charge is also applied on a per trunk basis but the charge applies only when the capacity ordered requires the installation of an additional trunk(s).

2. Service Rearrangements

All changes to existing services other than changes involving administrative activities only will be treated as a discontinuance of the existing service and an installation of a new service. The nonrecurring charge described in 1., preceding, will apply for this work activity. Moves that change the physical location of the point of termination are described below.

a. Moves Within the Same Building

When the move is to a new location within the same building, the charge for the move will be an amount equal to one half of the nonrecurring charge for the capacity affected. There will be no change in the minimum period requirements.

b. Moves to a Different Building

Moves to a different building will be treated as a discontinuance and start of service and all associated nonrecurring charges will apply. New minimum period requirements will be established for the new service. The Customer will also remain responsible for satisfying all outstanding minimum period charges for the discontinued service.

3. SWITCHED ACCESS

3.5 RATE REGULATIONS (Cont'd)

3.5.2 MINIMUM PERIOD

- A. The minimum period for which Switched Access Service is provided and for which charges are applicable, is three months.
- B. The following changes will be treated as a discontinuance of the existing service and an installation of a new service. All associated nonrecurring charges will apply for the new service and a new minimum period will be established.
- A move to a different building.
 - A change in type of service.
 - A change in Switched Access Service Interface Group.
 - Change in Switched Access Service traffic type.
 - A change in Out of Band Signaling connection.
- C. When Switched Access Service is disconnected prior to the expiration of the minimum period, charges are applicable for the balance of the minimum period.

The Minimum Period Charge for monthly billed services will be determined as follows:

For Switched Access Service, the charge for a month or fraction thereof is equal to the applicable minimum monthly charge for the capacity.

All applicable nonrecurring charges for the service will be billed in addition to the Minimum Period Charge.

3. SWITCHED ACCESS

3.5 RATE REGULATIONS (Cont'd)

3.5.3 MEASURING ACCESS MINUTES

Customer traffic to end offices will be measured (i.e., recorded or assumed) by the Company at End Office switches. Originating and terminating calls will be measured (i.e., recorded or assumed) by the Company to determine the basis for computing chargeable access minutes. In the event the Customer message detail is not available because the Company lost or damaged tapes or experienced recording system outages, the Company will estimate the volume of lost Customer access minutes of use based on previously known values. Access minutes will be recorded to the nearest one second for any particular call. Access minutes or fractions thereof are accumulated over the billing period for each end office and are then rounded up to the nearest access minute for each end office.

For originating calls over Feature Group B or D, usage measurement begins when the originating Feature Group B or D switch receives the first wink supervisory signal forwarded from the Customer's point of termination.

The measurement of originating call usage ends when the originating Feature Group B or D switch receives disconnect supervision from either the originating end user's end office, indicating the originating end user has disconnected, or the Customer's point of termination, whichever is recognized first by the switch.

For terminating calls over Feature Group B or D, the measurement of access minutes begins when the terminating Feature Group B or D switch receives answer supervision from the terminating end user's end office, indicating the terminating end user has answered.

The measurement of terminating call usage over Feature Group B or D ends when the terminating Feature Group B or D switch receives disconnect supervision from either the terminating end user's end office, indicating the terminating end user has disconnected, or the Customer's point of termination, whichever is recognized first by the switch.

3. SWITCHED ACCESS

3.5 RATE REGULATIONS (Cont'd)

3.5.4 ALLOWANCE FOR INTERRUPTIONS IN SERVICE

A. General

1. A service is interrupted when it becomes inoperative to the Customer, e.g., the Customer is unable to transmit or receive, because of a failure of a component furnished by the Company under this Tariff.
2. An interruption period begins when the Customer reports a service, facility or circuit to be inoperative and, if necessary, releases it for testing and repair. An interruption period ends when the service, facility or circuit is operative.
3. If the Customer reports a service, facility or circuit to be interrupted but declines to release it for testing and repair, the service, facility or circuit is considered to be impaired but not interrupted. No credit allowances will be made for a service, facility or circuit considered by the Company to be impaired.

3. SWITCHED ACCESS

3.5 RATE REGULATIONS

3.5.4 ALLOWANCE FOR INTERRUPTIONS IN SERVICE (Cont'd)

B. Limitations on Allowances

1. No credit allowance will be made for any interruption in service:
 - a. Due to the negligence of or noncompliance with the provisions of this Tariff by any person or entity other than the Company, including but not limited to the Customer or other common carriers connected to the service of the Company;
 - b. Due to the failure of power, equipment, systems, connections or services not provided by the Company;
 - c. Due to circumstances or causes beyond the control of the Company;
 - d. During any period in which the Company is not given full and free access to its facilities and equipment for the purposes of investigating and correcting interruptions;
 - e. During any period in which the Customer continues to use the service on an impaired basis;
 - f. During any period when the Customer has released service to the Company for maintenance purposes or for implementation of a customer order for a change in service arrangements;
 - g. That occurs or continues due to the Customer's failure to authorize replacement of any element of special construction; and
 - h. That was not reported to the Company within thirty (30) days of the date that service was affected.

2. Use of Another Means of Communications

If the Customer elects to use another means of communications during the period of interruption, the Customer must pay the charges for the alternative service used.

C. Cancellation For Service Interruption

Cancellation or termination for service interruption is permitted only if any circuit experiences a single continuous outage of 8 hours or more or cumulative service credits equaling 16 hours in a continuous 12 month period. The right to cancel service under this provision applies only to the single circuit which has been subject to the outage or cumulative service credits.

3. SWITCHED ACCESS

3.5 RATE REGULATIONS

3.5.5 SWITCHED ACCESS RATE CATEGORIES - KENTUCKY

Rates for certain switched access charges are dependent upon the Zone in which they originate or terminate. For Kentucky rates, each Zone is defined based upon the Incumbent Local Exchange Carrier also offering service in that territory. If the Zones are not specified for a rate, the rate applies to all areas. The Zones are:

- Zone 1 Territory also served by AT&T SE Region
- Zone 2 Territory also served by Cincinnati Bell
- Zone 3 Territory also served by Windstream East
- Zone 4 Territory also served by Windstream West
- Zone 5 Territory served by All Other Carriers

(N)

(N)

3. SWITCHED ACCESS

3.6 RATES AND CHARGES

3.6.1 NONRECURRING

NONRECURRING

		(D)
		(D)
A. Indiana		(T)
• Administration Charge, per order	\$ 50.00	
• Installation, per first trunk	100.00	
• Installation, per subsequent trunk	15.00	
• Connection Charge, per trunk	15.00	
B. Kentucky		(T)
• Per Location - Per Order -		
- Per First Trunk	\$150.00	
- Per Subsequent Trunk	36.00	

3. SWITCHED ACCESS

3.6 RATES AND CHARGES (Cont'd)

3.6.2 RECURRING

A. Carrier Common Line

**RECURRING RATE
PER MOU**

1. Originating/Terminating

• Indiana	0.000000
• Kentucky	0.000000
• Ohio	0.000000

(D)

3. SWITCHED ACCESS

3.6 RATES AND CHARGES

3.6.2 RECURRING (CONT'D)

B. Transport

1. Tandem Switched Transport

**RECURRING RATE
PER MOU**

a. Transport Termination[1]

• Indiana	0.0001030	(R)
• Ohio	0.0001030	(R)
• Kentucky		
Zone 1	0.0001680	
Zone 2	0.0006000	
Zone 3	0.0000479	
Zone 4	0.0002480	(R)
Zone 5	0.0001680	

[1] For jointly provided Transport, one-half of the Transport Termination rate is assessed.

3. SWITCHED ACCESS

3.6 RATES AND CHARGES

3.6.2 RECURRING

B. Transport(Cont'd)

1. Tandem Switched Transport

RECURRING RATE
PER MOU

b. Transport Mileage, per mile

		(R)
		(R)
• Indiana	0.0000130	
• Ohio	0.0000130	
• Kentucky		
Zone 1	0.0000200	
Zone 2	0.0001170	(R)
Zone 3	0.0000142	(R)
Zone 4	0.0001000	
Zone 5	0.0000200	

3. SWITCHED ACCESS

3.6 RATES AND CHARGES

3.6.2 RECURRING

B. Transport(Cont'd)

1. Tandem Switched Transport

**RECURRING RATE
PER MOU**

c. Tandem Switching

• Indiana	0.0018560
• Ohio	0.0018560
• Kentucky	
Zone 1	0.0012180
Zone 2	0.0020010
Zone 3	0.0004230
Zone 4	0.0000000
Zone 5	0.0012180

(D)

3. SWITCHED ACCESS

3.6 RATES AND CHARGES

3.6.2 RECURRING

B. Transport (Cont'd)

2. Dedicated Transport

a. Entrance Facilities

Arrangements for Entrance Facilities are as set forth in Section 4, following, for Special Access Service.

b. Direct-Trunked Transport

Arrangements for Direct-Trunked Transport are as set forth in Section 4, following, for Special Access Service.

c. Multiplexing

Arrangements for Multiplexing are set forth in Section 4, following, for Special Access Service.

3. SWITCHED ACCESS

3.6 RATES AND CHARGES

3.6.2 RECURRING (Cont'd)

C. End Office Switching

**RECURRING RATE
PER MOU**

1. Local Switching

• Indiana	0.0031160	(R)
• Ohio	0.0031160	(R)
• Kentucky		
Zone 1	0.0021260	(R)
Zone 2	0.0036714	
Zone 3	0.0013823	
Zone 4	0.0037750	(R)
Zone 5	0.0021260	(R)

3. SWITCHED ACCESS

3.6 RATES AND CHARGES

3.6.2 RECURRING (Cont'd)

C. End Office Switching

**RECURRING RATE
PER MOU**

2. Common Trunk Port

• Indiana	0.0003710
• Ohio	0.0003710
• Kentucky	
Zone 1	0.0008000
Zone 2	0.0009680
Zone 3	0.0007029
Zone 4	0.0011840
Zone 5	0.0008000

(D)

3. SWITCHED ACCESS

3.6 RATES AND CHARGES

3.6.2 RECURRING

C. End Office Switching (Cont'd)

	MONTHLY RATE	
3. Dedicated Trunk Port, per trunk		(D)
		(D)
• Indiana		
- DS0/VG	4.28	
- DS1	102.69	
• Kentucky		
- DS0/VG	9.47	
- DS1	139.98	

3. SWITCHED ACCESS

3.6 RATES AND CHARGES

3.6.2 RECURRING

D. 8XX Toll-Free Access

**RECURRING RATE
PER QUERY**

1. Customer Identification Charge

• Indiana	0.0023040
• Ohio	0.0023040
• Kentucky	
Zone 1	0.0042100
Zone 2	0.0023910
Zone 3	0.0090200
Zone 4	0.0010000
Zone 5	0.0042100

(D)

3. SWITCHED ACCESS

(D)

(D)

3. SWITCHED ACCESS

(D)

(D)